

NEST BOXES FOR WOOD DUCKS

U.S. Fish and Wildlife Service □ DEPARTMENT OF THE INTERIOR

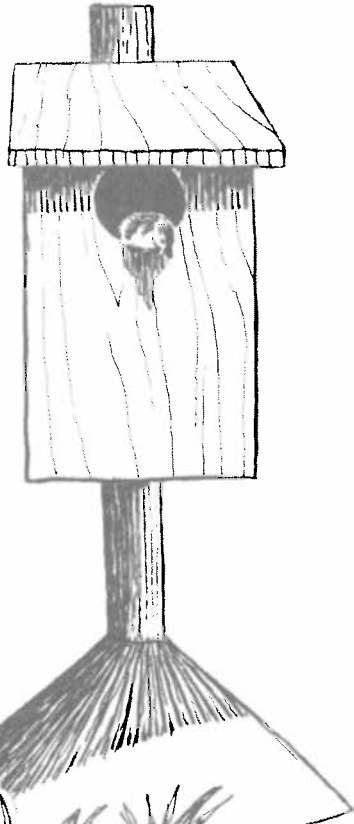

PROPERTY OF COLUMBIA NATIONAL
FISHERIES RESEARCH LAB LIBRARY

Library
Columbia National Fisheries
Research Laboratory
Route 1
Columbia, Missouri 65201

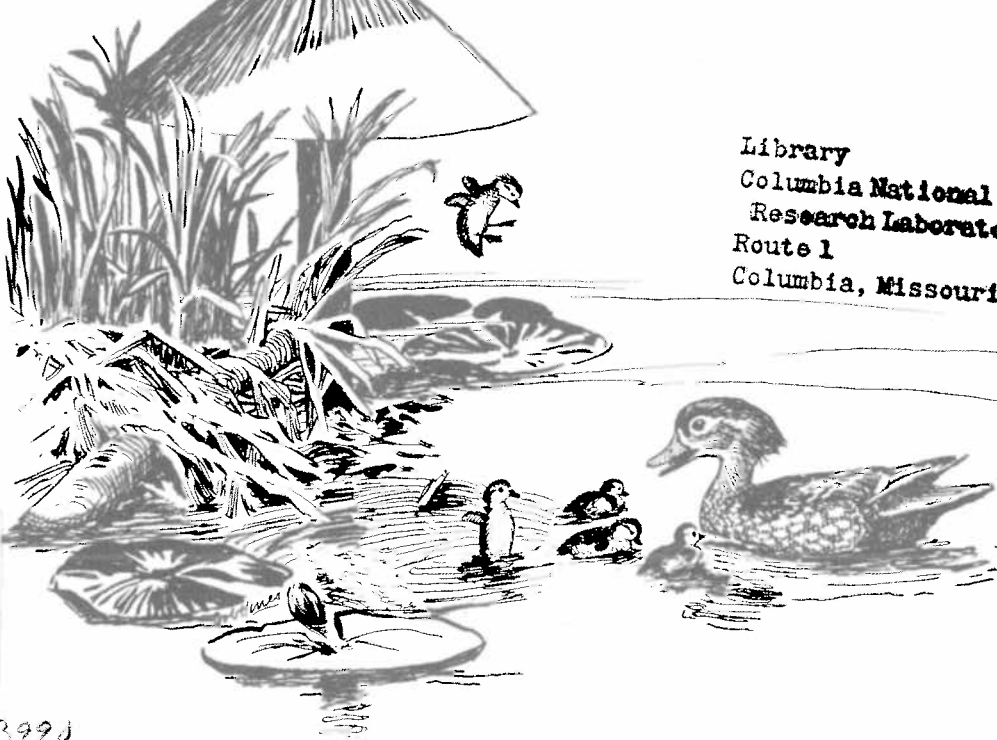

SERIALS
Wild.
Leaf.
510
copy 2

245399J

WOOD DUCKS

Wood ducks are secretive little birds. They prefer to while away the hours among the brush and tangle of a beaver pond, button-bush swamp, or a willow brake. They will leave the sanctuary of these retreats to feed in corn or soybean stubble, but will seldom be found far from cover.

There was a time, around the turn of the century, that for a number of reasons wood duck populations became alarmingly low. Fortunately, through the determined efforts of conservationists, the various State game departments, and the combined cooperation of the Governments of Canada and the United States, steps were taken in time to save the "woodies." The result was one of the most notable conservation achievements to date.

Today there are several million wood ducks in North America, and their future is relatively secure.

Nevertheless, there are still problems for wood ducks, the most significant of which relates to availability of suitable nesting sites. Unlike most other ducks, the woodie is a tree-nesting duck. They prefer a hole in a hollow tree, much like a woodpecker. Unfortunately, as the Nation's demand for more timber and agricultural products increases, so does the pressure on natural nesting cavities. Forest management geared to maximum economic production provides minimal accommodation for the type of unsound trees that provide the nesting cavities.

Moreover, increased national and world consumption of agricultural crops such as grain and soybeans has resulted in the conversion of literally millions of woodlands to agricultural production. While scientists generally agree that this trend has not yet impacted significantly on continental populations of wood ducks, the situation is being viewed with concern.

Biologists have known since the early 1900's that the wood duck will nest in artificial structures, but it was not until the early 1930's that the idea was taken seriously. Since then the U.S. Fish and Wildlife Service and the various State game departments have initiated numerous nest box programs that have resulted in varying degrees of success.

In most instances when wood ducks are deprived of their preferred nest trees, they will accept artificial nest boxes. Furthermore, experience has shown that woodies hatched in boxes become "imprinted" and often prefer them over natural tree cavities.

Short of a major national program, it is unlikely that nest boxes will have any significant effect on continental populations of wood ducks. However, for those who appreciate the beauty and enchantment of wood ducks, a nest box hobby or project can be especially rewarding. And, there is substantial evidence that nest box programs can indeed have pronounced beneficial effects on wood duck populations locally.

The first prerequisite for producing wood ducks is availability of suitable habitat for rearing the young. Anyone who contemplates putting up nest boxes should first determine if there are lakes, ponds, or streams nearby that provide sufficient food and escape cover for ducklings to survive those crucial weeks to flight stage. A representative of the nearest State or Federal conservation agency can probably make that determination.

If rearing habitat is available and wood ducks are known to frequent the area, then it is desirable to proceed with the nest box project.

EDUCATION CENTER
NATIONAL FISHERIES
DOMINANT RESEARCH CENTER

U.S.A.C.

WOOD DUCK BOXES

This brochure describes the materials and procedures for making and erecting wood duck boxes. It is important to remember that the box is also attractive to many other creatures that will compete with the wood duck for a nest site, and to a greater number of predators that will, given an opportunity, kill the ducks or destroy the eggs. Competitors include squirrels, owls, starlings, and woodpeckers. Predators include snakes, mink, raccoons, opossums, rats, wildcats, housecats, and a host of others. In short, a box improperly erected and unprotected can become a death trap for the wood duck. *So, it should be done properly or not at all!*

1. Boxes should be erected on posts (wood or metal) but may be put on trees, provided the trees selected can be made as predator proof as posts. Boxes should not be placed on or near trees where they are vulnerable to predators that may reach them from above by means of other trees. Similarly, boxes should always be protected from below by a metal shield. The shield may be flat or conical, but in any case it should extend in all directions at least 18 inches from the tree or post supporting the nest box. If flying predators or competitors such as starlings or woodpeckers become troublesome, there may be some relief in changing the design and attitude of the box (figure 1).

2. Ideally, boxes should be placed over or at the edge of a water body and should be about 10 feet above the ground or water surface. If the water level fluctuates, the shield should be at least 3 feet above the high water level. However, ducks will accept boxes at substantial distances from water. When hatching occurs away from the water, the female will immediately lead the young overland to water. Because at that time the ducklings are extremely vulnerable to predators, this factor should be carefully considered in the selection of box sites.

3. Maintenance is extremely important. Since wood ducks do not collect nest materials, a nest base such as sawdust or wood shavings, 3 inches deep, must be furnished. Boxes should be cleaned each year and repaired as needed. The use of boats or of access facilities such as ladders can involve significantly greater maintenance costs as well as potential safety hazards.

Therefore, the maintenance of large numbers of boxes can be time consuming and expensive. If economics is a factor, the location of boxes on land where they can be reached readily by vehicle is preferable to the more aesthetically pleasing locations over water.

4. Wood ducks, unlike most other ducks, will tolerate close nesting by other wood ducks. Thus, boxes may be placed in clusters, and two or more may even be mounted on the same post without significant negative impact on nesting success.

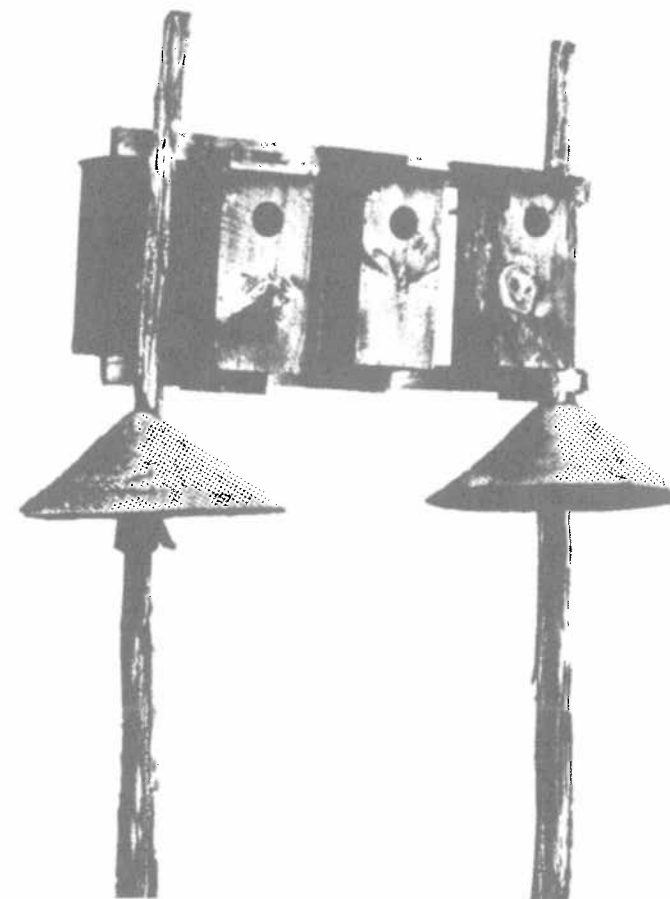

STANDARD WOOD DUCK NESTING BOX

This nesting box is cheap to build, easy to maintain and, properly safe-guarded, inaccessible to such nest predators as raccoons, snakes, and squirrels.

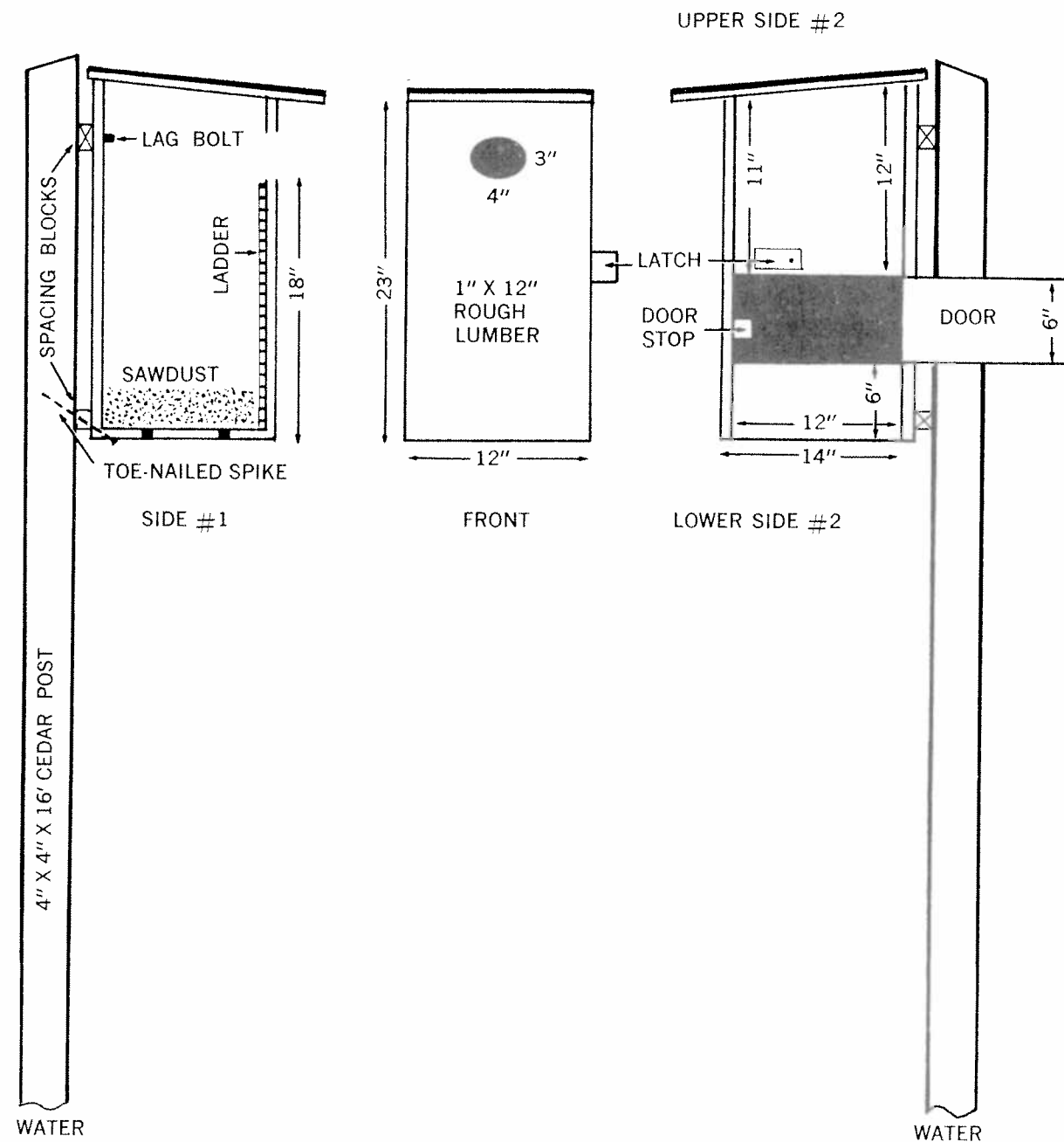

The box should be constructed of unplanned cedar, cypress, or other weather-resistant lumber. It should NOT be painted, stained, or creosoted. As the diagram indicates, the entrance should be oval-shaped with the broadest distance horizontal. On the inside front of the box, beneath the hole, a strip of screen or hardware cloth should be tacked to provide the ducklings a means of escaping the box.

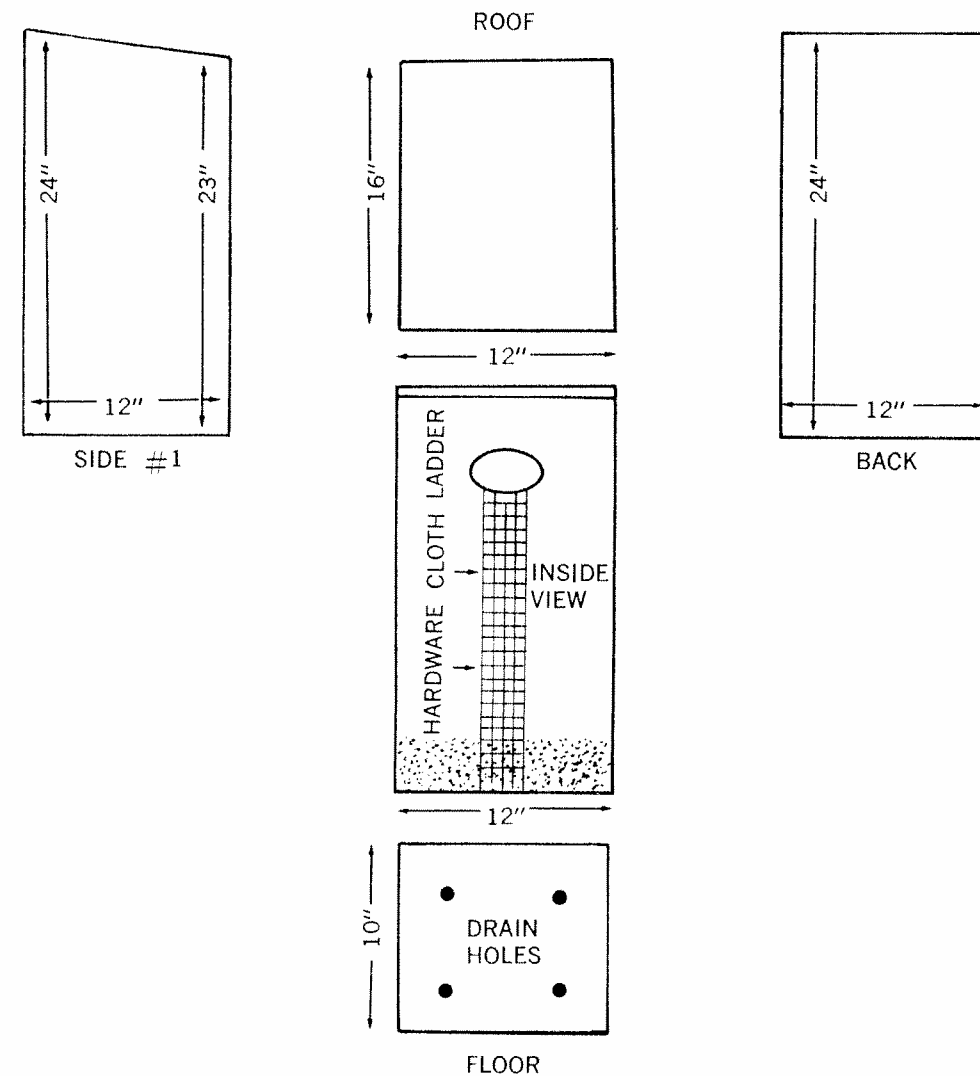

STANDARD WOOD DUCK NESTING BOX

This nesting box is cheap to build, easy to maintain and, properly safe-guarded, inaccessible to such nest predators as raccoons, snakes, and squirrels.

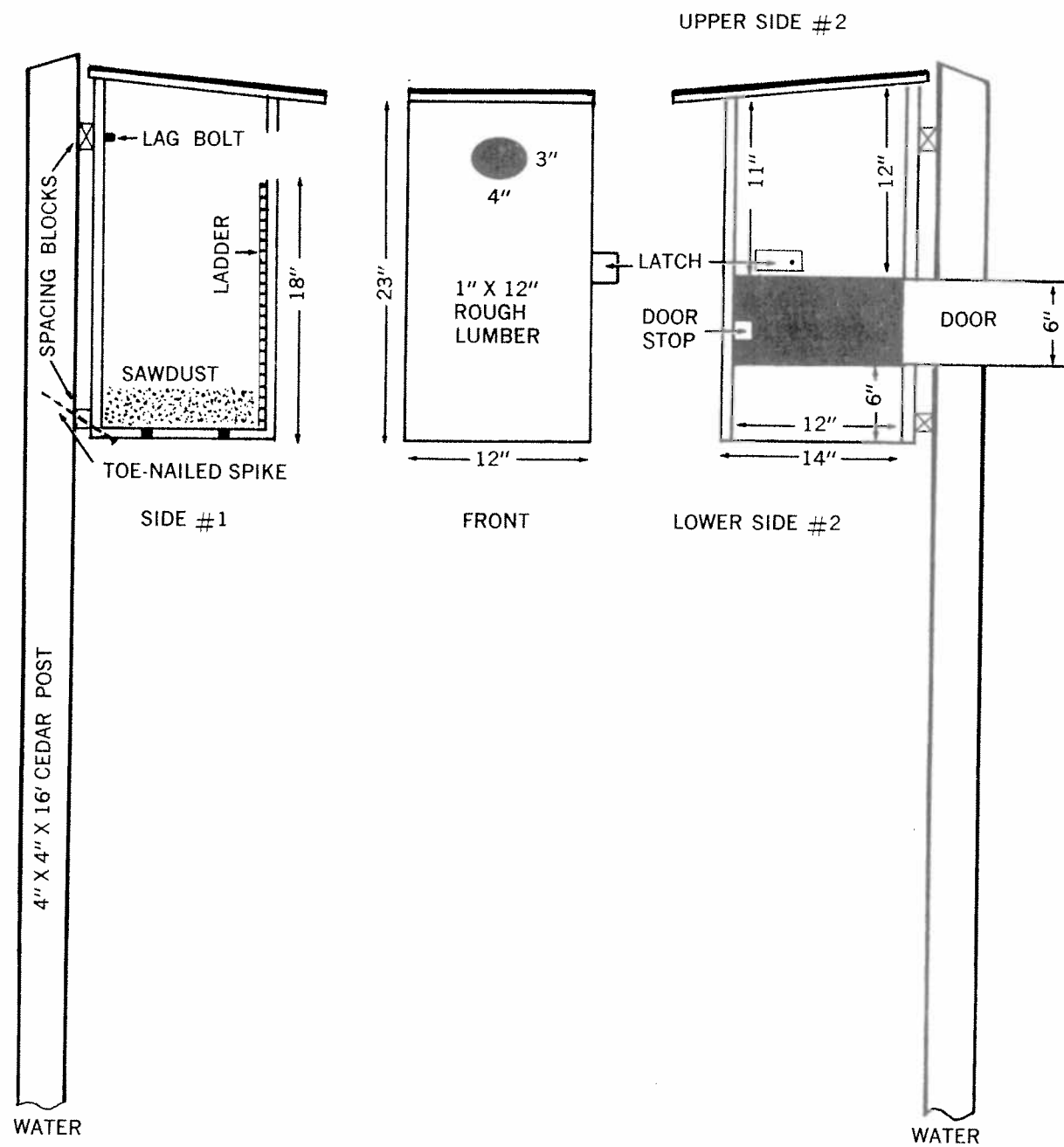

The box should be constructed of unplanned cedar, cypress, or other weather-resistant lumber. It should NOT be painted, stained, or creosoted. As the diagram indicates, the entrance should be oval-shaped with the broadest distance horizontal. On the inside front of the box, beneath the hole, a strip of screen or hardware cloth should be tacked to provide the ducklings a means of escaping the box.

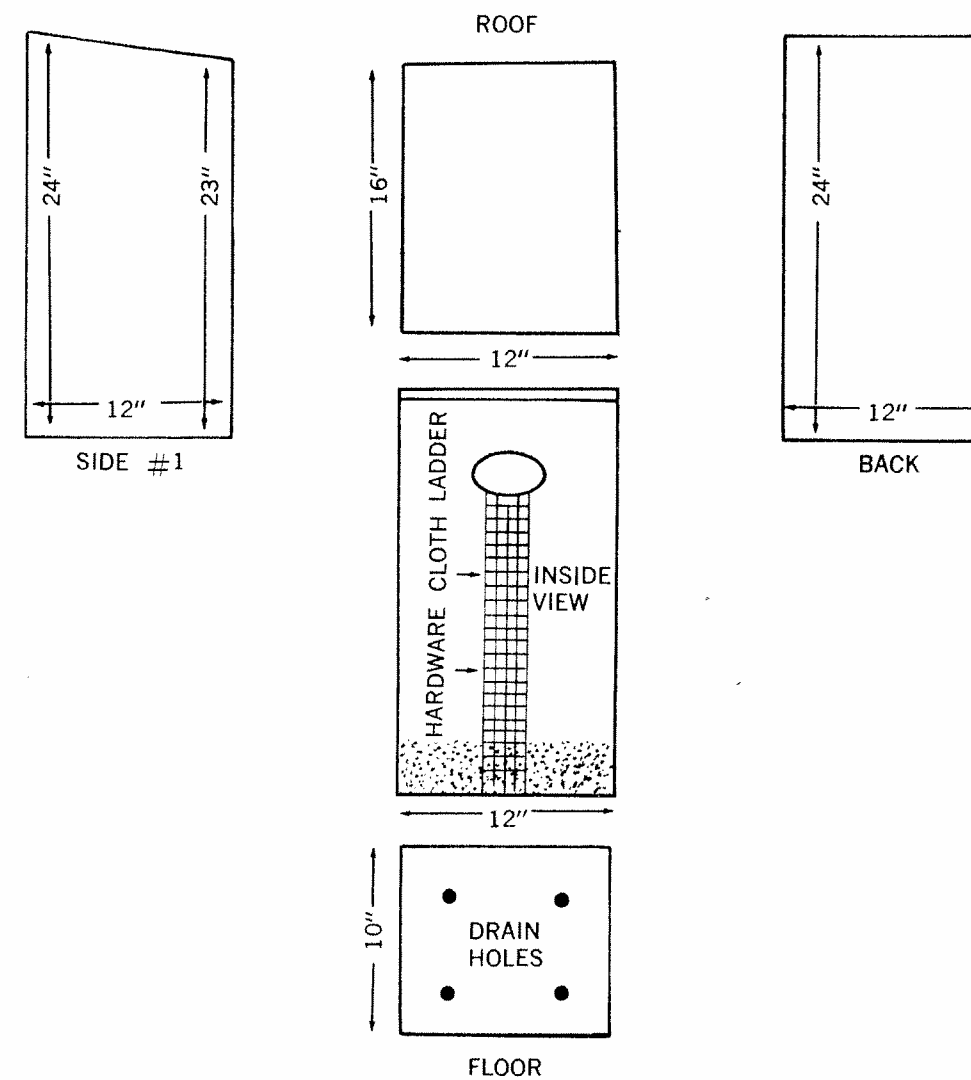

MATERIALS

- Nails 25—8 or 10-penny, zinc-coated.
- Spike 1—4+ inch.
- Lag bolt 1— $\frac{1}{4}$ -inch, 6 inches long.
- Hinge 1—3-inch cabinet + screws.
- Hardware Cloth 18-inch strip cut at least 3 inches wide. (All sharp ends should be bent under.)
- Post 1, 4" X 4", 16 feet long. (Should be cypress, cedar, or a preservative-treated wood.)
- Plus Enough sawdust, wood-chips, or crumbled rotten wood to form a 3-inch nest base in each box.

Use rust-proof screws or nail that are long enough to hold securely despite rough handling and weathering.

Bore four $\frac{1}{4}$ -inch drainage holes through the floor.

Tack a strip of $\frac{1}{4}$ -inch mesh hardware cloth cut about 18" X 3" from the bottom of the box to the hole. This is necessary in order for the ducklings to be able to climb out the nest.

Spray the inside of the box with lysol or other disinfectant prior to the nesting season to discourage wasp and bees from moving in.

Wood ducks will nest in close proximity, but for the best results, the boxes should be grouped in clusters of half-a-dozen or so spaced so that each is no less than 50 feet from any other.

Each nest box must be cleaned and replenished with sawdust or wood chips each January.

10 LINEAR FEET OF 1' X 12" ROUGH LUMBER

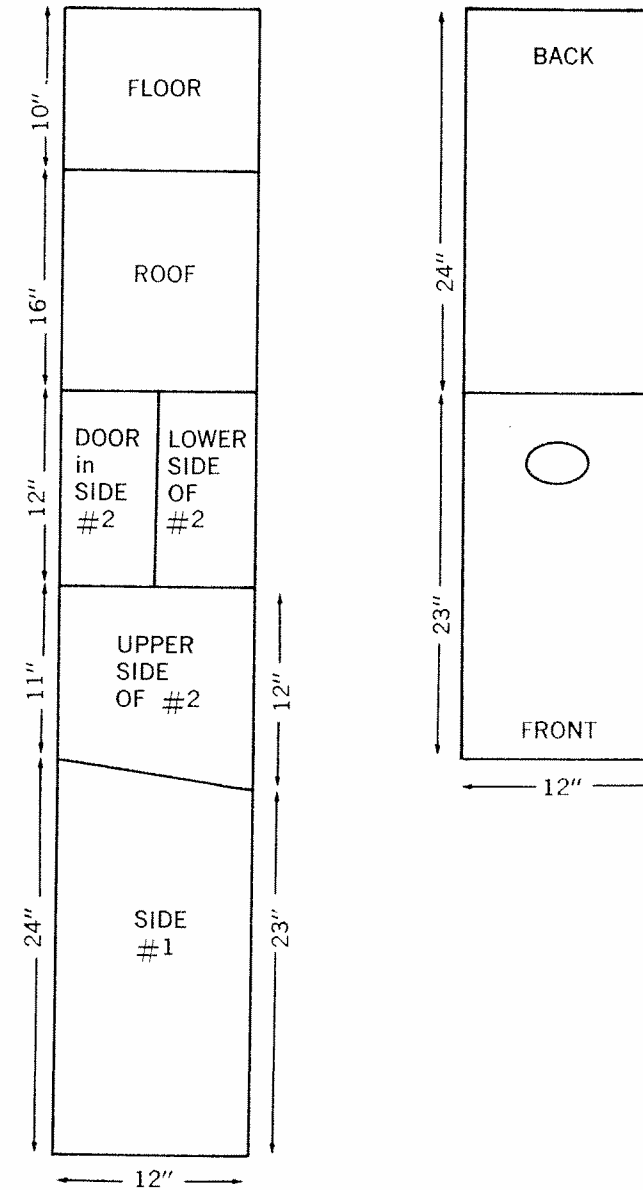

PREDATOR GUARD

Cone-shaped, sheet-metal guard for protecting nest structures from predators. At right is layout for cutting 3 predator guards from a 3' x 8' sheet of 26-gauge galvanized metal. When installing the guard, overlap the cut edge to the dotted line. To facilitate cutting (on solid lines only) follow the sequence of numbers. Make circular cuts in counterclockwise direction. To make initial cut on line A-B, make a slot at A with a cold chisel. Use tinsnips and wear leather gloves.

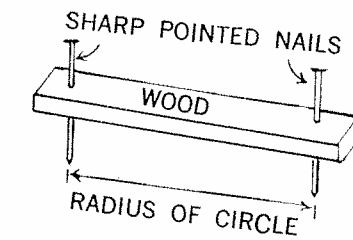
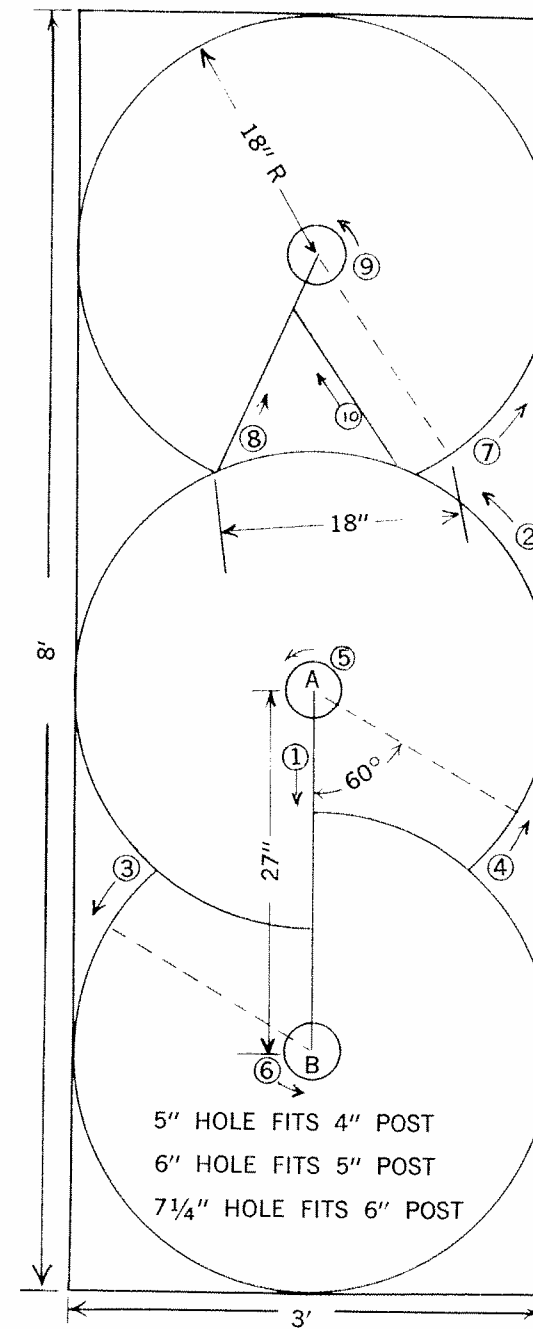
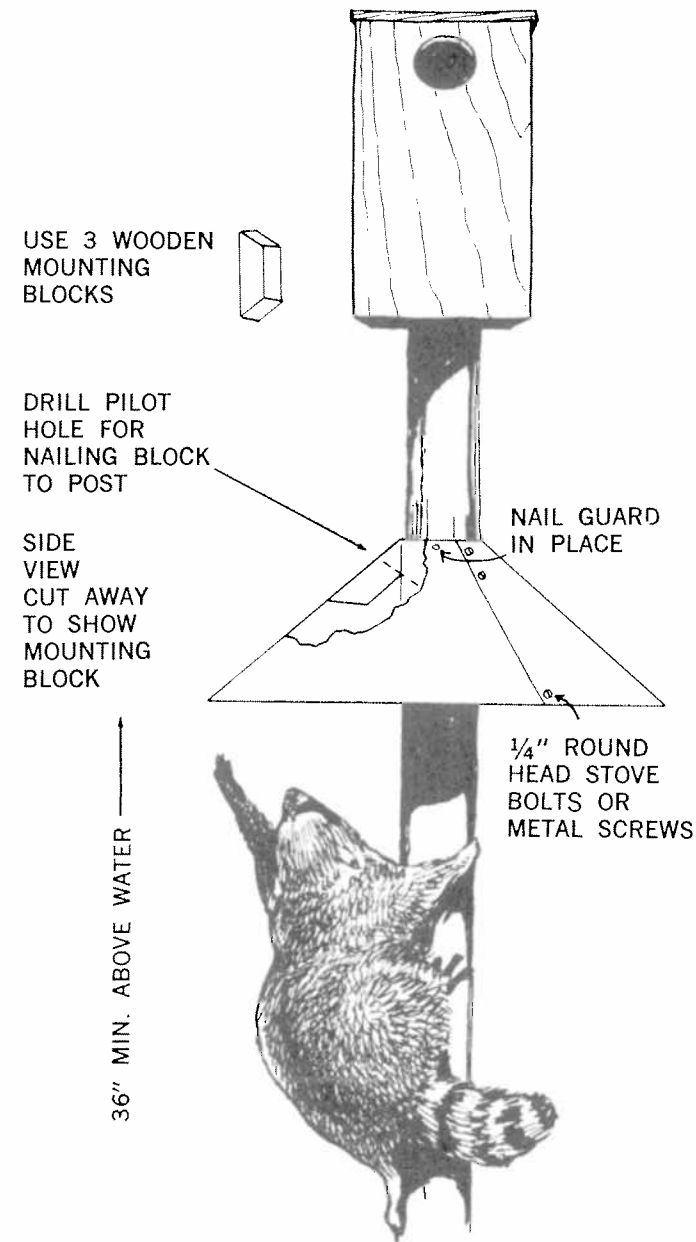

HOME MADE COMPASS FOR SCRIBING METAL

VARIATIONS IN MOUNTING AND PREDATOR GUARD

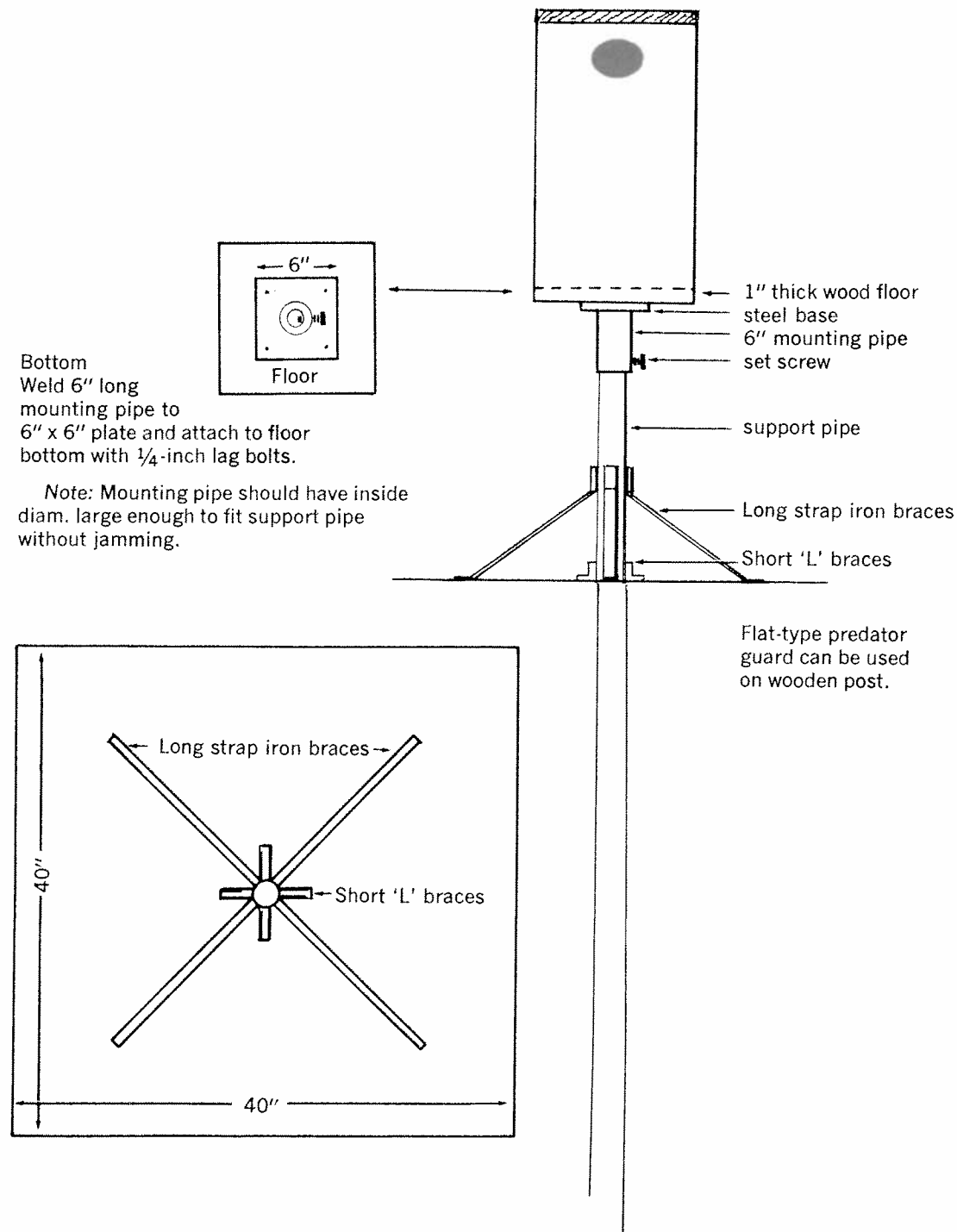

STOVEPIPE NESTING SHELTER

The horizontal, starling-proof box, should be mounted on a channel-type steel fence post as shown below. Removal of the first and fourth prongs leaves holes about 9 inches apart. The lower hole is used for attaching the box to post with a stove bolt. The upper hole is used for fastening the ends of two support wires which are hooked through the opposite side of the nesting cylinder near each end. The box should be tightly attached to post to prevent wind from tearing it loose.

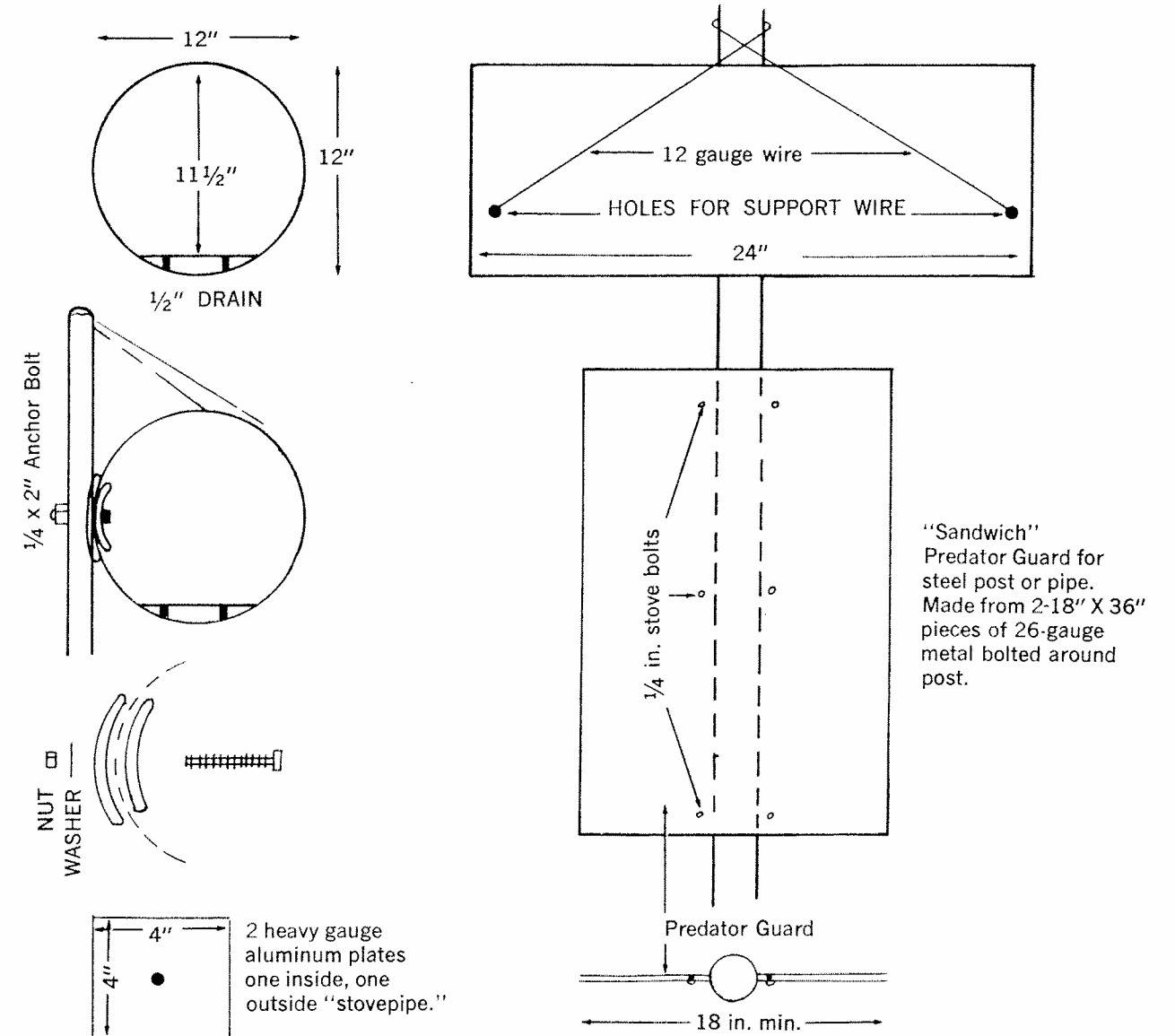

MATERIALS

- Metal 2, 18" X 36" min. pcs. of 26 gauge metal
+ 8¼" bolts for sandwich predator guard.
- "Stovepipe" 1, 12" diameter galvanized furnace pipe,
24 inches long.
- Wire 10 feet of 12-gauge galvanized wire.
- Nails 2 dozen, 10-penny.
- Wood Can be rough, 1—1½ inch mill ends. One
(for back) 12" wide. Other, 8" X 12" (for
front).
- Fittings 1, ¼" X 2" stove bolt and nut, 2 heavy
gauge metal plates which have been bored
out for the bolt and shaped to fit curve of
furnace pipe, and 1 lock washer.
- Steel post 1, 8–10 feet long, with ¼ inch hole bored
about 18" from the top for anchor bolt.

DEPARTMENT OF THE INTERIOR

As the Nation's principal conservation agency, the Department of the Interior has responsibility for most of our nationally owned public lands and natural resources. This includes fostering the wisest use of our land and water resources, protecting our fish and wildlife, preserving the environmental and cultural values of our national parks and historical places, and providing for the enjoyment of life through outdoor recreation. The Department assesses our energy and mineral resources and works to assure that their development is in the best interest of the Nation. The Department also has a major role in the protection of Indian reservation communities and territories under U.S. administration.

WILDLIFE LEAFLET 510 M
WL 510 is a revision of WL 45

FOR MORE INFORMATION, WRITE TO:

Director
U.S. Fish and Wildlife Service
Department of the Interior
Washington, D.C. 20240

Reports USFWS Wild Leaf 510
U.S. Fish and Wildlife
Service.
Nest boxes for wood ducks

DATE	ISSUED TO
	Reports USFWS Wild Leaf 510 U.S. Fish and Wildlife Service. Nest boxes for wood ducks

INFORMATION CENTER
NATIONAL FISHERIES
CONTAMINANT RESEARCH CENTER
ROUTE 1
COLUMBIA, MO 65201

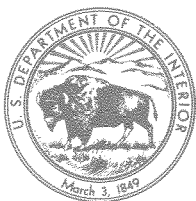

WILDLIFE LEAFLET 510 MAY 1976 WASHINGTON, D.C.
WL 510 is a revision of WL 458 March 1964

☆ U.S. GOVERNMENT PRINTING OFFICE : 1976 O-204-469

For sale by the Superintendent of Documents, U.S. Government Printing Office
Washington, D.C. 20402 - Price 35 cents

Stock No. 024-010-00415-1

There is a minimum charge of \$1.00 for each mail order